

# Inside Micrometers

## SERIES 345, 145 — Caliper Type

### FEATURES

- Caliper type jaws are made of high-grade, tool steel.
- Locking clamp for positive locking of spindle.
- Satin-chrome finished.
- A special holder is available to be used with Mitutoyo Micrometer Stand.
- Supplied in fitted plastic case. Over 175mm / 4" supplied in wooden case.



345-350-10

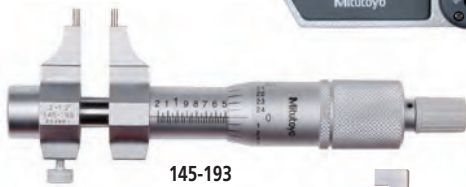

145-193

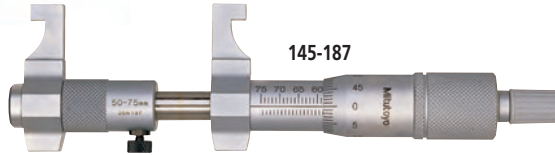

145-187

### SPECIFICATIONS

Metric		
Range	Order No.	Accuracy
5 - 30mm	345-250-10	±5µm
25 - 50mm	345-251-10	±6µm

Inch/Metric		
Digital model		
Range	Order No.	Accuracy
.2 - 1.2" / 5-30mm	345-350-10	±.00025"
1 - 2" / 25-50mm	345-351-10	±.0003"

Metric		
Range	Order No.	Accuracy
5 - 30mm	145-185	±5µm
25 - 50mm	145-186	±6µm
50 - 75mm	145-187	±7µm
75 - 100mm	145-188	±8µm
100 - 125mm	145-189	±9µm
125 - 150mm	145-190	±9µm
150 - 175mm	145-191	±10µm
175 - 200mm	145-192	±10µm
200 - 225mm	145-217	±11µm
225 - 250mm	145-218	±11µm
250 - 275mm	145-219	±12µm
275 - 300mm	145-220	±12µm

Inch		
Range	Order No.	Accuracy
.2 - 1.2"	145-193	±.00025"
1 - 2"	145-194	±.0003"
2 - 3"	145-195	±.00035"
3 - 4"	145-196	±.0004"

### DIMENSIONS

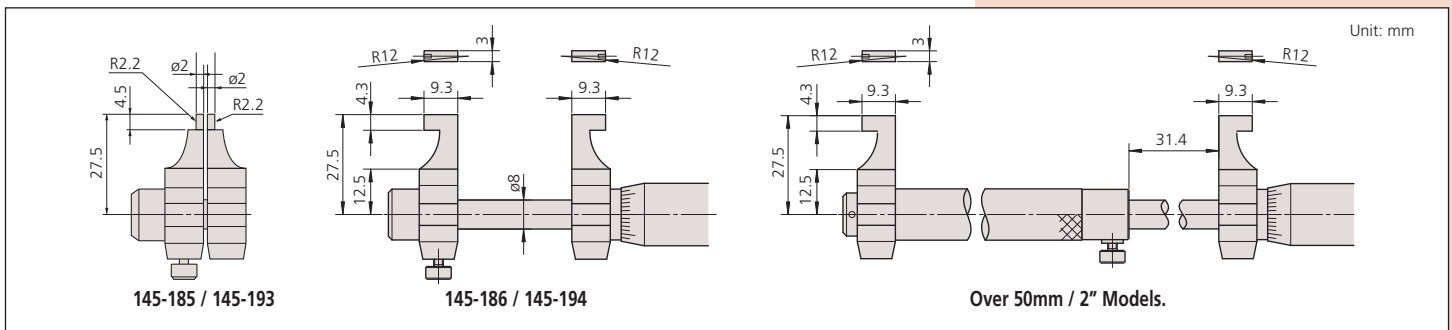

### Technical Data

Accuracy: Refer to the list of specifications.  
(excluding quantizing error for digital models)  
Resolution\*: 0.01mm or .00005"/0.001mm  
Graduation\*\*: 0.01mm or .001"  
Measuring faces: Carbide tipped  
Display\*: LCD  
Battery\*: SR44 (1 pc.), 938882  
Battery life\*: Approx. 1.2 years under normal use  
\*Digital models \*\*Analog models

### Function of Digital Model

Origin-set, Zero-setting, Data hold, Data output, inch/mm conversion (inch/mm models)  
Alarm: Low voltage, Counting value composition error  
Function Lock  
2 Presets

### Optional Accessories

- 05CZA662: SPC cable with data switch 1m / 40"
- 05CZA663: SPC cable with data switch 2m / 80"
- : Setting ring (See page C-30.)
- 300401: Cap for stand holder
- 300400: Stand holder

